



4th October 2022

Parametric filter design for the “LA3600” audio processor.



alastair john underwood, GW0AJU
updated article

CAD Spec LA3600

Roughly working out the bandwidth with the Q = 4 of each gyrator filter setting, the perhaps best centre frequency arrangement could be 375Hz, 675Hz, 900Hz, 1600Hz, 2700Hz, the values based on the filter circuit design "Q", the bandpass width just touch the edge of the neighbour filter response, hopefully then providing a smooth balance of the audio range from 300Hz to 3000Hz, a full width SSB filter in today's DSP radios.

The manufacture datasheet lists the design component equation :-

$$f_o = \frac{1}{2\pi \sqrt{C1, C2, R1, R2}} \quad (R1=1.2k\Omega, R2=68k\Omega \text{ on-chip resistor})$$

Below is an image of the manufactures design application circuit

Sample Application Circuit

Unit (resistance: Ω , capacitance: F)

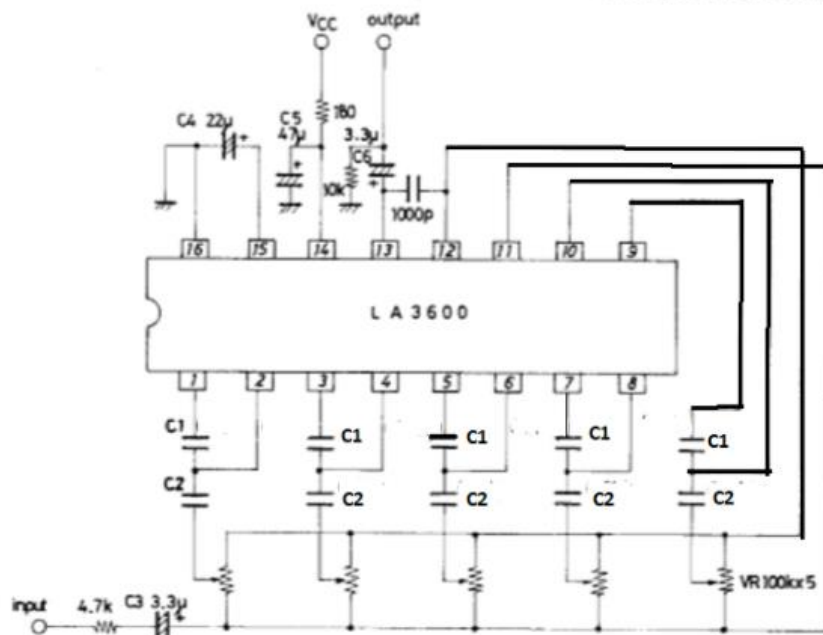

$$f_o = \frac{1}{2\pi \sqrt{C1, C2, R1, R2}} \quad (R1=1.2k\Omega, R2=68k\Omega \text{ on-chip resistor})$$

Description of external parts

- C1, C2 : Capacitors used to fix f_o (resonance frequency)
- C2 : Input capacitor. Decreasing the capacitor value lowers the frequency response at low frequencies.
- C3 : Input capacitor. Decreasing the capacitor value lowers the frequency response at low frequencies.
- C4 : Decoupling capacitor. Decreasing the capacitor value makes the effect of power supply stronger, whereby ripple is liable to occur.
- C5 : Power capacitor.
- C6 : Output capacitor. Decreasing the capacitor value lowers the frequency response at low frequencies.

Equivalent Circuit Block Diagram

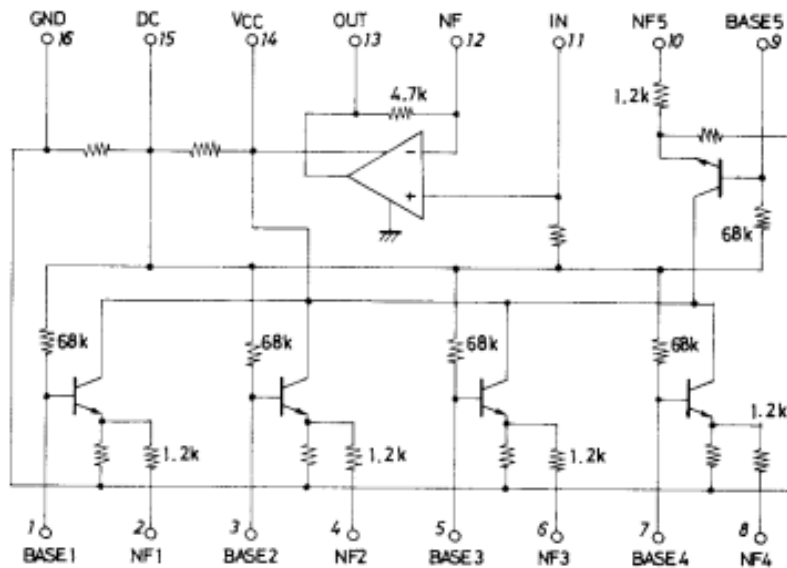

Unit (resistance: Ω , capacitance: F)

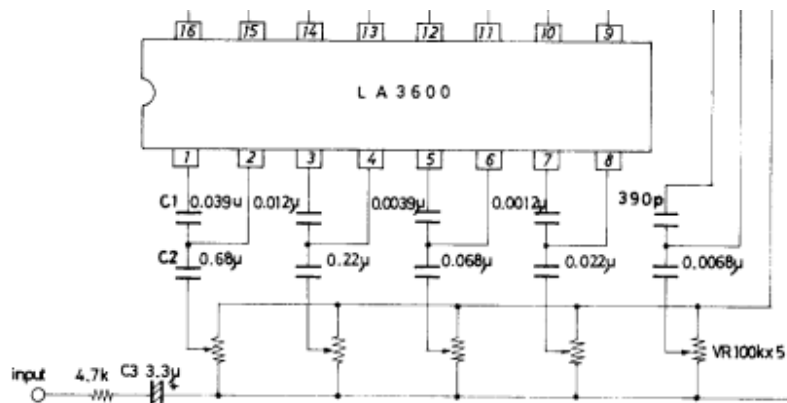

f_0 (resonance frequency)

In the sample application circuit, f_0 for each of 5 bands is set as follows :

$f_0=108\text{Hz}, 343\text{kHz}, 1.08\text{kHz}, 3.43\text{kHz}, 10.8\text{kHz}$

$$f_0 = \frac{1}{2\pi \sqrt{C1, C2, R1, R2}} \quad (R1=1.2\text{k}\Omega, R2=68\text{k}\Omega \text{ on-chip resistor})$$

Description of external parts

C1, C2 : Capacitors used to fix f_0 (resonance frequency)

C2 : Input capacitor. Decreasing the capacitor value lowers the frequency response at low frequencies.

C3 : Input capacitor. Decreasing the capacitor value lowers the frequency response at low frequencies.

C4 : Decoupling capacitor. Decreasing the capacitor value makes the effect of power supply stronger, whereby ripple is liable to occur.

C5 : Power capacitor.

C6 : Output capacitor. Decreasing the capacitor value lowers the frequency response at low frequencies.

The ending component values are now listed below within the following graphic. Note the "R_add", which equates to a series resistance to "R_one", where "R_one" relates to the 1200 ohms internal resistor of the LA3600 circuit chip.

The additional resistance is placed, for example relating to pin2, placed between pin2 and the junction of C1 and C2. Likewise for the remaining filter circuits.

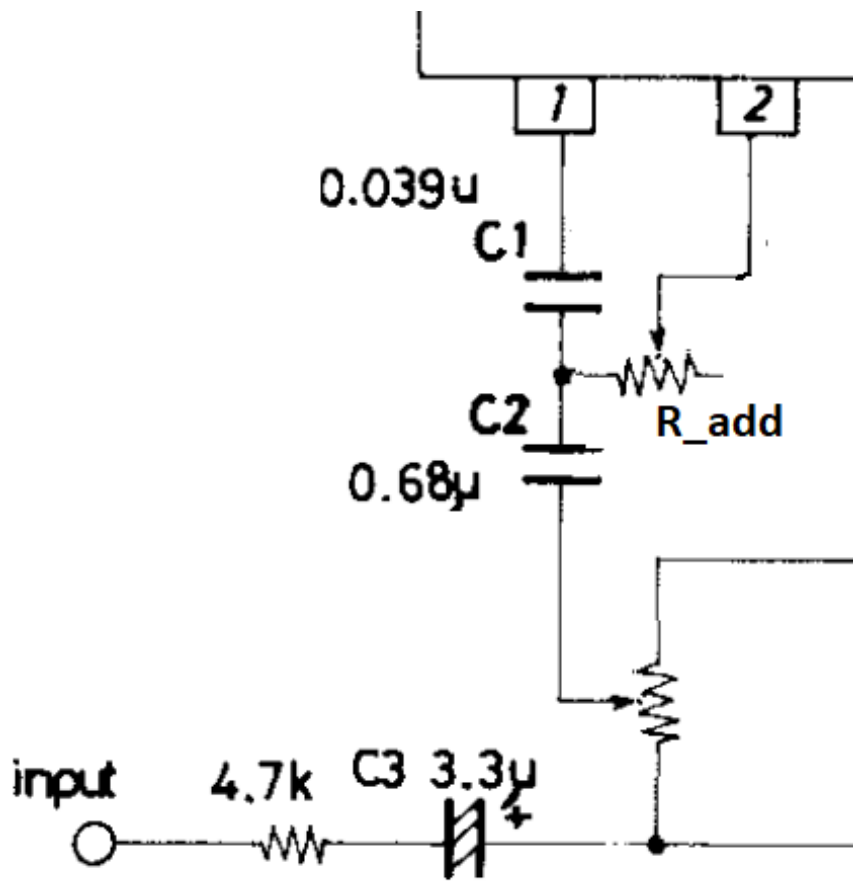

The additional series resistance, principally tunes the bandpass filter to the correct centre frequency, as required per the circuit application design specifications.

Note, the "R_add" values are in this case within the reach of a 20K ohm trim pot, and that the values of C1 and C2, are as near to a preferred value as possible.

However, the snag here is perhaps the difference of each transistor stage signal gain. It would seem probable that the 68K ohm base current limiting resistor and the 1200 ohms emitter resistor may well play apart to govern the transistor stage signal gain.

By using buffer or load additional resistance, may help tune the capacitor to the required time constant, but may also upset the transistor stage signal gain performance.

So, looking again to how the parametric circuit functions, it seems that the transistor circuit is based around a Colpitts's RC oscillator. Diagram shown below :-

Equivalent Circuit Block Diagram

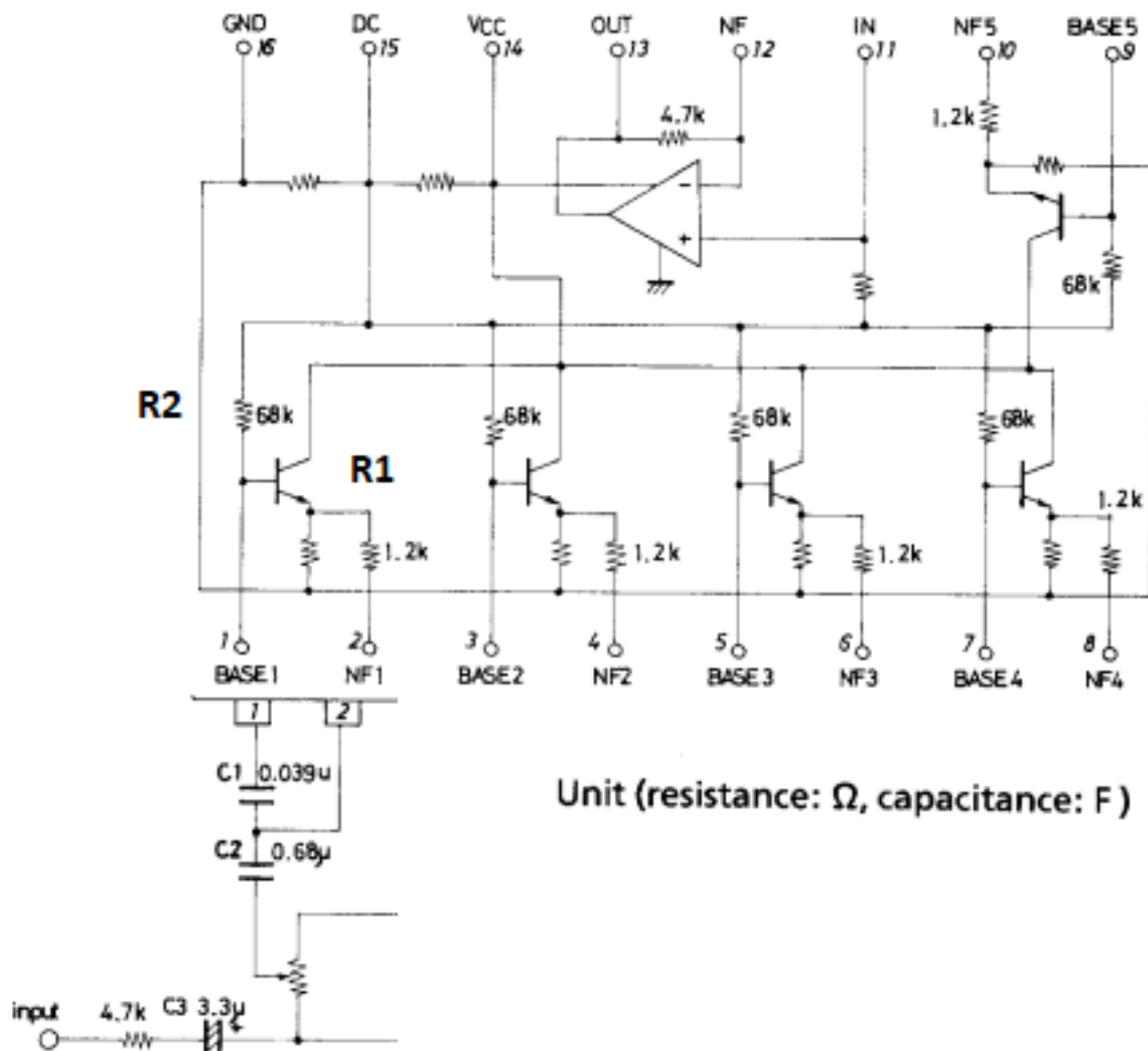

Assume that the input AF audio signal is used to excite the illustrated transistor stage into an RC tuned filter action. The degree of interaction depended upon the variable resistor wiper position, thus the audio input signal tap.

Looking at the above circuit, R1 is the 1200-ohm resistor, and R2 the 68K ohm resistance.

From examining the above circuit, there seems to be two different time constants at play.

Time constant number one is combined from R1 and C2, thus 'F Bw', while time constant number two relates to R2 and C1 'F res'.

Using equation shown below :-

$$\text{RC Frequency} = \frac{1}{2\pi RC}$$

Calculating the 1st time constant R2 '68K ohms' and C1 '39nF' equates 'F res' as 60Hz, while the 2nd time constant of R1 '1200 ohms' and C2 '680nF' equates 'F Bw' as 195Hz, or in essence the 1st stage bandpass equates to as 'F Bw' = +/- 100Hz.

The manufacturer diagram lists the first filter at 108Hz, 'F res = C1 & R2', but somehow I have the feeling that the near 60Hz may be close too 'F res' or in error, unless from the diagram C2 or R1 are miss quoted within the data sheet.

If quoted sheet values are correct, the calculated 60Hz centre frequency as to the quoted 108Hz 'F_res', for the first parametric filter stage.

The Colpitts RC oscillator thus in theory acts as a boot strap amplifier, such as the position of the wiper then determines the degree of boost or reduction of the audio signal around 200Hz.

I measured the circuit resistance between pins 15 and 1, and measured 61K ohms. Checking around the chip, the 68K ohm resistor varies from essentially 60K to 62K ohms. Measuring the 1200 ohms resistor, I found was not so possible.

However, if the datasheet circuit diagram 1st stage filter bandwidth is recalculated, be assuming a type error that 1200 ohms is 2100ohms, then the 1st stage 'F bw' = +/- 55Hz. The +/- bandwidth would be the 3dB points for the 1st stage parametric filter.

The determined 'F res = 60Hz' centre spot with 'F Bw = +/- 55Hz' bandpass, the resistance of R1 originally the quoted 1200ohms, my just be possible to equate as 2100ohms.

The trick would be to position each spot filter stage centre frequency, with the +/- bandwidth 3dB points placed near or close to each other, thus providing an individual filter adjustment, without affecting each other filter stage setting.

Looking at the op-amp within the chip, shows a feedback resistance of 4700 ohms. It is perhaps best to arrange the overall op-amp circuit as an AC coupled signal summation amplifier.

Using thus say 1000 ohms input resistor on each AC coupled stage wiper tap top end connection, would equate to a signal gain of some 4.7 times or at " $20\log(\text{voltage ratio})$ ", equates as 13dBV, or should perhaps say an overall " $\pm 13\text{dBV}$ ".

I noticed that the if the wiper feed directly from the top end of the variable resistor, then without the AC summation amplifier design use, there would not be an input resistance to the op-amp circuit. By using an AC coupled summation amplifier design, this problem is overcome.

However, the next may be problem, the balance between the boost and reduction. To overcome this problem, the top and bottom end of the variable resistor wiper, may need to be loaded or padded with a resistor, thus balance out the boost and reduction to the $\pm 13\text{dBV}$.

If a lower boost or cut is required, increase the input resistor from 1000 ohm to say 2200 ohms, which would then equate to a boost or cut as $\pm 6.5\text{dBV}$.

This brings another point, as for a rule of thumb, try not use a volume control pot greater than 47K ohms, as the electrical body signal of the mains hum, 50Hz in the UK, will find its way onto the audio signal, while holding the control knob. A YouTube video shows 10Kohm trim pots used, so perhaps either 10K ohm or a 47K ohm could be used.

If one is handy with solder irons etc, a self-build, then try so, but do remember that other radio hams sourced parts and modules, spend time building for our own convenience, to essentially drop into ones say 40m qrp project.

However, I have found a reference to a transistorised gyrator circuit, which is the frequency tuning that is used within the LA3600 chip circuit. Below illustrates the circuit:

Gyrator filter circuit

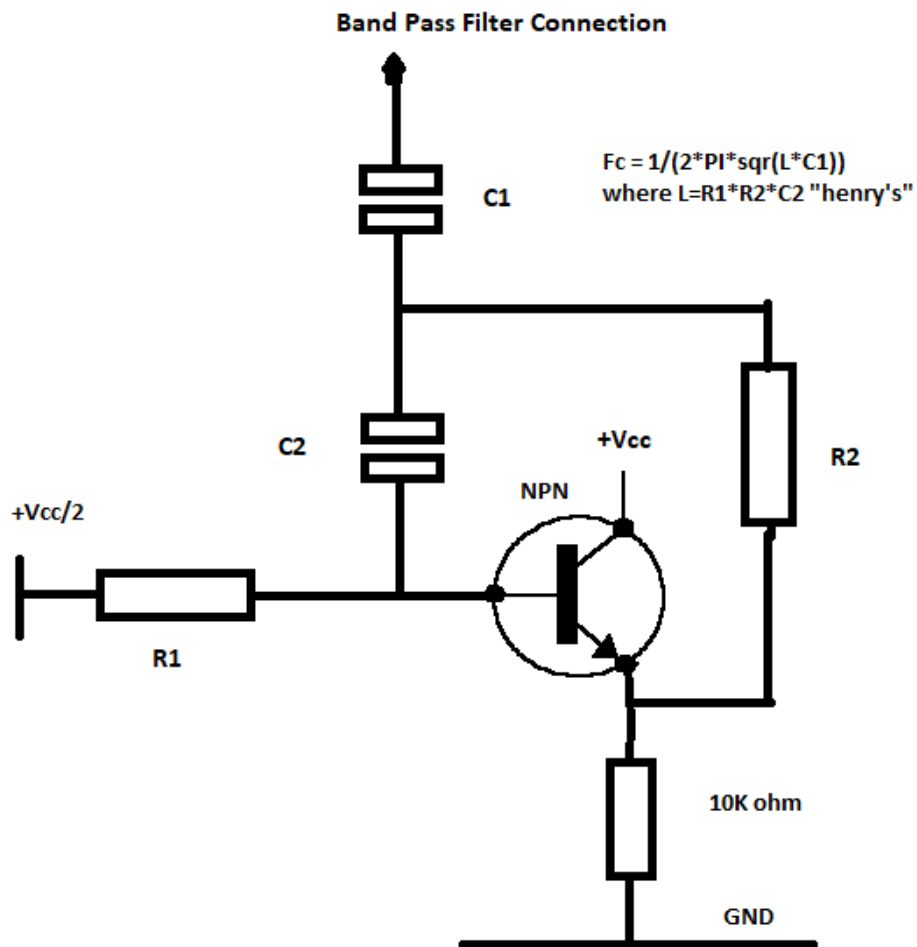

The website url: [Gyrator Filters \(sound-au.com\)](http://Gyrator Filters (sound-au.com)) is an interesting website to study for the many answers related to the many questions circulating around parametric filtering principles.

Section "14 - Gyrator Based Graphic Equaliser ", of the website URL listed above, explains a basic parametric filter application circuit.

I think that is about it, have fun.

Regards,

Alastair GW0AJU